

1500 GALLON

POLYLOK CAST IN RISER PANS

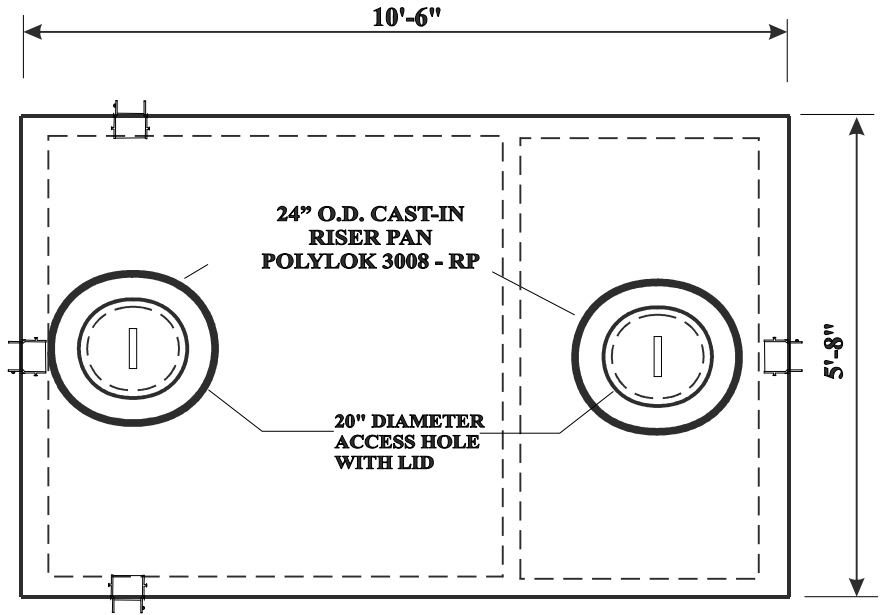
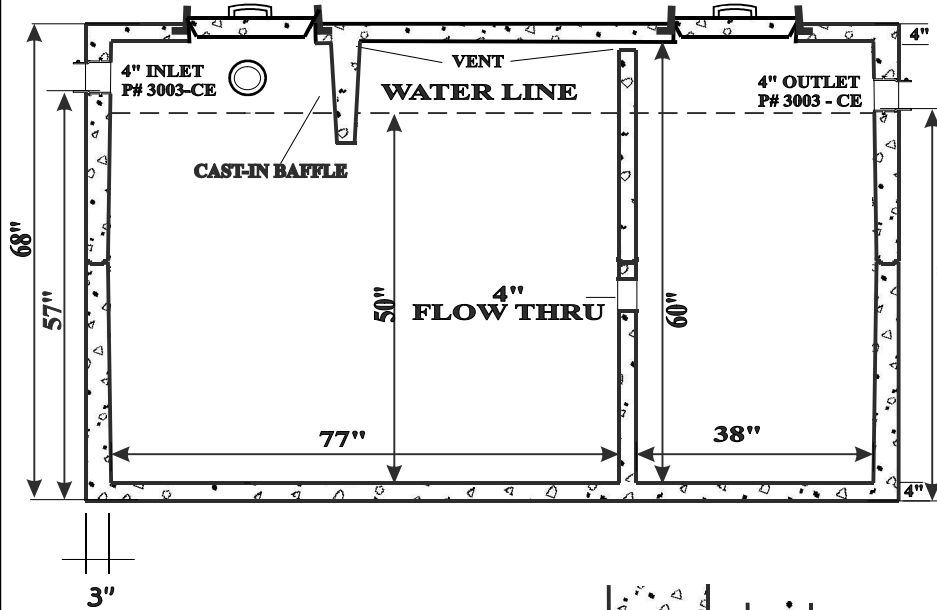

**POLYLOK 24" X 3" JOINT DETAIL
RISER PAN**

**1" x 1" BUTYL
SEALANT**

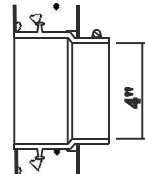

**RUBBER BOOT
DETAIL**

4" BOOT STANDARD

**CAST-IN WATERTIGHT RUBBER BOOTS
AVAILABLE IN 2", 4" AND 6" SIZES**

PROJECT		
CUSTOMER		
DRAWN BY		DATE
COST		
APPROVED BY		
DATE		

VOLUME - CAPACITY:	FABRICATION SPECS:
LARGE CHAMBER SPECS:	TONGUE & GROOVE JOINT, SEALED WITH 1" X 1" BUTYL SEALEANT
CAPACITY: 77" X 61" X 50" = 1010 GAL	STRUCTURAL FIBER REINFORCED CONCRETE - 5000 PSI
GALLONS PER INCH = 20.2 GAL	REINFORCEMENT - PROFIBER S PREMIERE STRUCTURAL FIBER
SMALL CHAMBER SPECS:	
CAPACITY: 38" X 61" X 50" = 499 GAL.	
GALLONS PER INCH = 9.98 GAL	
OVERALL WEIGHT : 13,000 LBS.	



29150 C DRIVE NORTH, ALBION, MI 49224
PHONE: 517-629-4800 EXT:210