

# 2000 GALLON

POLYLOK CAST IN RISER PANS

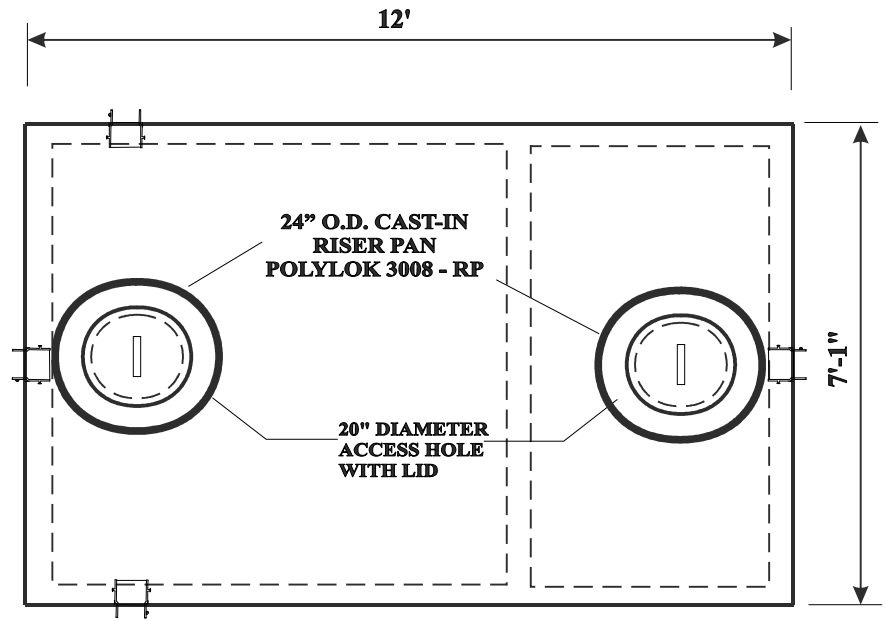
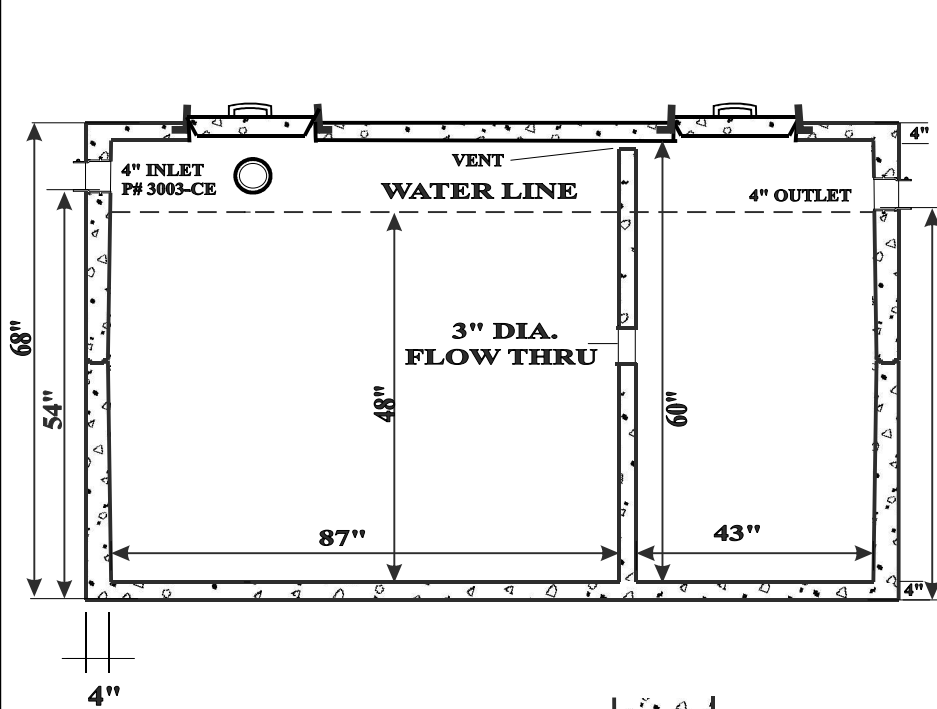

**POLYLOK 24" X 3" RISER PAN**

**1" x 1" BUTYL SEALANT**  
**JOINT DETAIL**

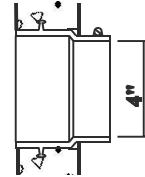

**4" BOOT STANDARD**  
**CAST-IN WATERTIGHT RUBBER BOOTS**  
**AVAILABLE IN 2", 4" AND 6" SIZES**

**RUBBER BOOT**  
**DETAIL**

PROJECT		
CUSTOMER		
DRAWN BY		DATE
COST		
APPROVED BY		
DATE		

VOLUME - CAPACITY:	FABRICATION SPECS:
<b>LARGE CHAMBER SPECS:</b>	TONGUE & GROOVE JOINT, SEALED WITH 1" X 1" BUTYL SEALEANT
CAPACITY: 87" X 76" X 48" = 1374 GAL	STRUCTURAL FIBER REINFORCED CONCRETE - 5000 PSI
GALLONS PER INCH = 28.6 GAL	REINFORCEMENT - PROFIBER S PREMIERE STRUCTURAL FIBER
<b>SMALL CHAMBER SPECS:</b>	
CAPACITY: 43" X 76" X 48" = 679 GAL.	
GALLONS PER INCH = 14.14 GAL	
OVERALL WEIGHT : 21,000 LBS.	



29150 C DRIVE NORTH, ALBION, MI 49224  
PHONE: 517-629-4800 EXT:210