

1000 GALLON BOTTOM PUMP

POLYLOK CAST IN RISER PANS

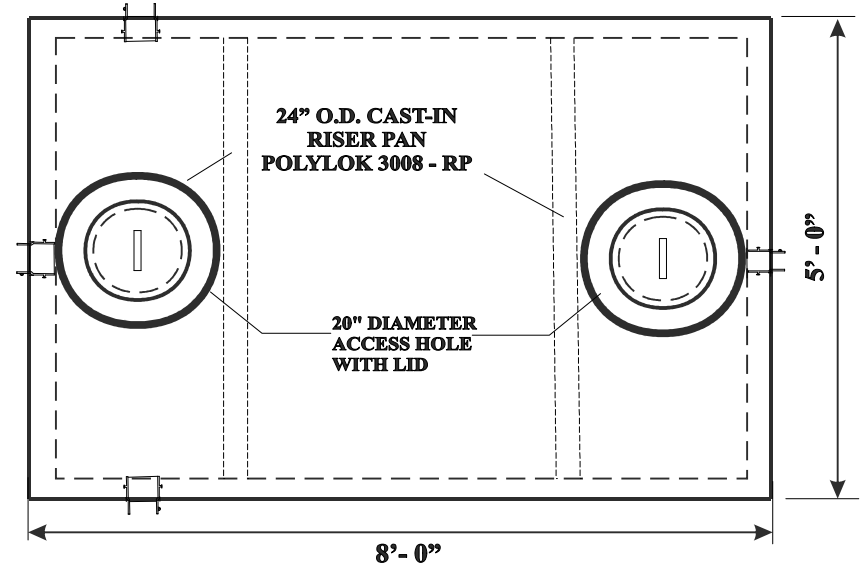
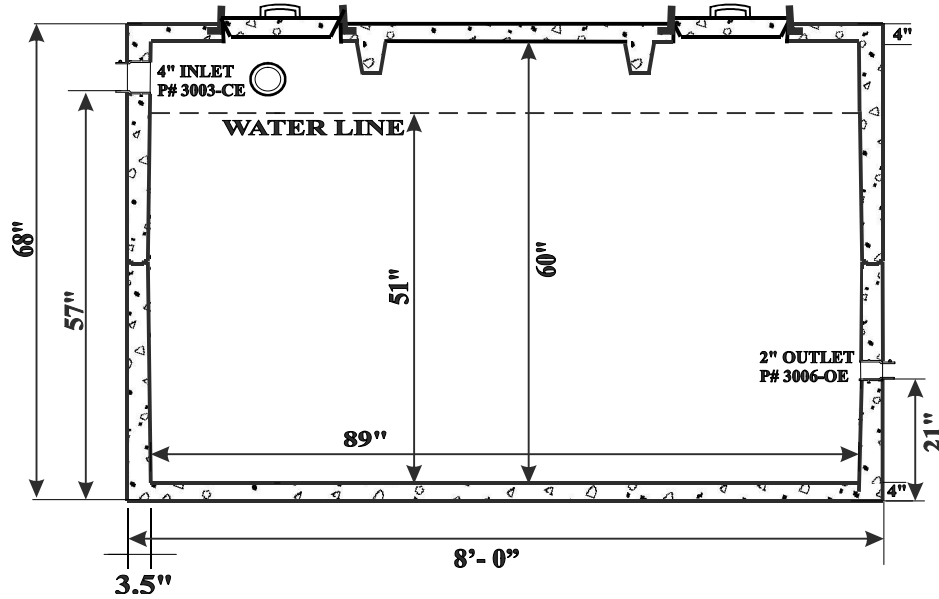

POLYLOK 24" X 3" RISER PAN

1" x 1" BUTYL SEALANT

JOINT DETAIL

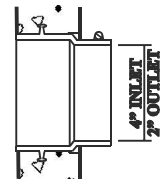
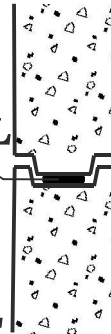

RUBBER BOOT DETAIL

**4" BOOT STANDARD INLET
2" BOOT STANDARD OUTLET**

PROJECT		
CUSTOMER		
DRAWN BY		DATE
COST		
APPROVED BY		
DATE		

VOLUME - CAPACITY:	FABRICATION SPECS:
CAPACITY: 89" X 52" X 51" = 1021 GAL	TONGUE & GROOVE JOINT, SEALED WITH 1" X 1" BUTYL SEALEANT
GALLONS PER INCH = 20.02 GAL	STRUCTURAL FIBER REINFORCED CONCRETE - 5000 PSI
	REINFORCEMENT - PROFIBER S PREMIERE STRUCTURAL FIBER
OVERALL WEIGHT : 9,000 LBS.	



29150 C DRIVE NORTH, ALBION, MI 49224
PHONE: 517-629-4800 EXT:210