

3500 GALLON

POLYLOK CAST IN RISER PANS

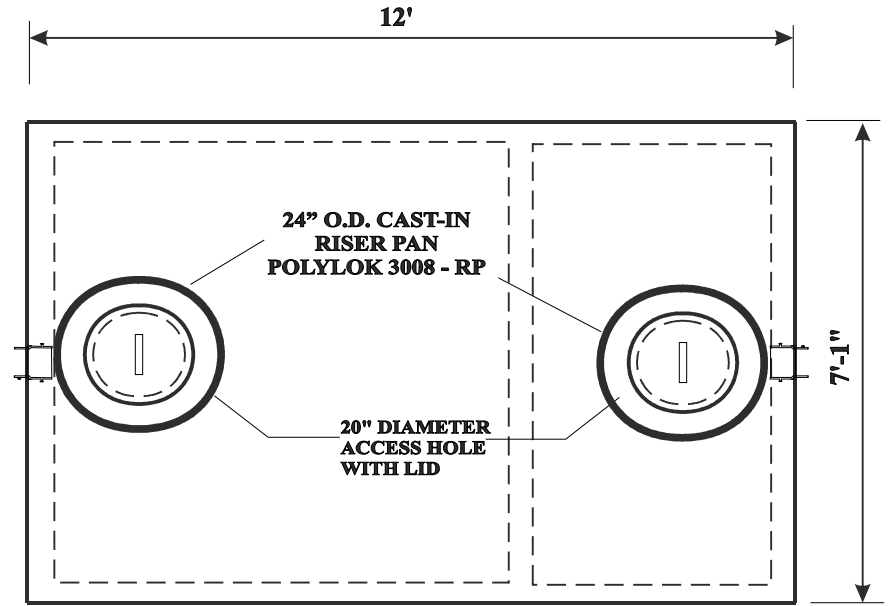
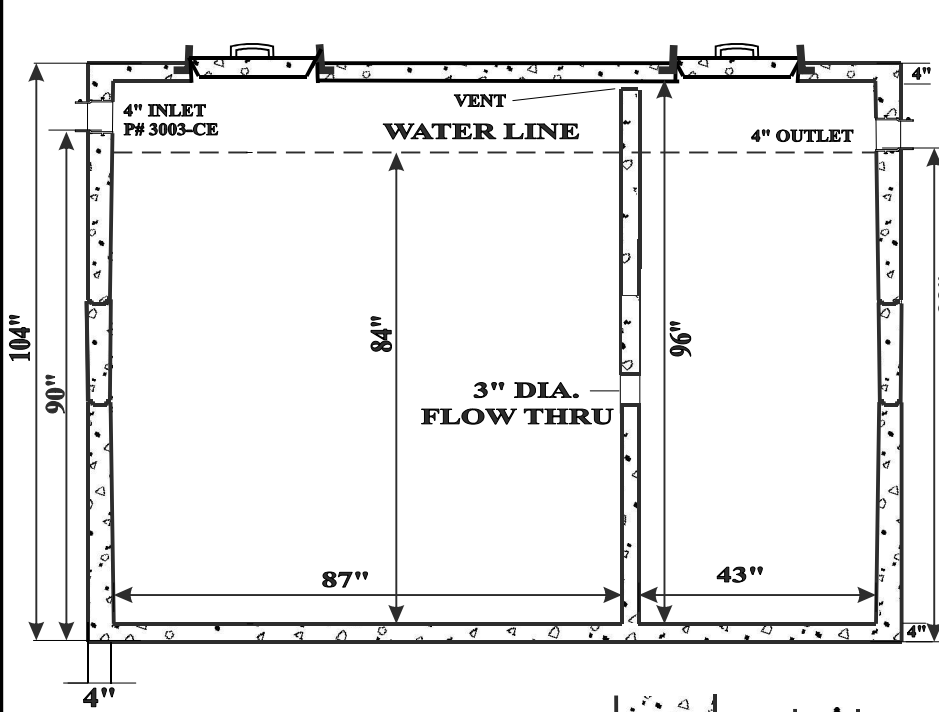

POLYLOK 24" X 3" RISER PAN

1" x 1" BUTYL SEALANT
JOINT DETAIL

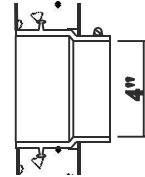

4" BOOT STANDARD
CAST-IN WATERTIGHT RUBBER BOOTS
AVAILABLE IN 2", 4" AND 6" SIZES

RUBBER BOOT
DETAIL

PROJECT		
CUSTOMER		
DRAWN BY		DATE
COST		
APPROVED BY		
DATE		

VOLUME - CAPACITY:	FABRICATION SPECS:
LARGE CHAMBER SPECS:	TONGUE & GROOVE JOINT, SEALED WITH 1" X 1" BUTYL SEALEANT
CAPACITY: 87" X 76" X 84" = 2404 GAL	STRUCTURAL FIBER REINFORCED CONCRETE - 5000 PSI
GALLONS PER INCH = 28.6 GAL	REINFORCEMENT - PROFIBER S PREMIERE STRUCTURAL FIBER
SMALL CHAMBER SPECS:	
CAPACITY: 43" X 76" X 84" = 1188 GAL.	
GALLONS PER INCH = 14.14 GAL	
OVERALL WEIGHT : 25,000 LBS.	



29150 C DRIVE NORTH, ALBION, MI 49224
PHONE: 517-629-4800 EXT:210