

# 500 GALLON PUMP PACKAGE

POLYLOK CAST IN RISER PANS & RISERS

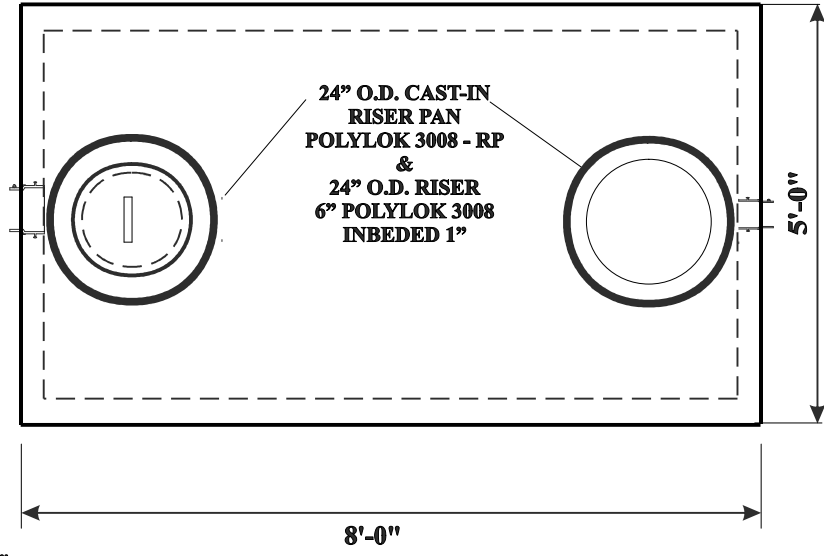

**POLYLOK**  
24" X 12" RISER

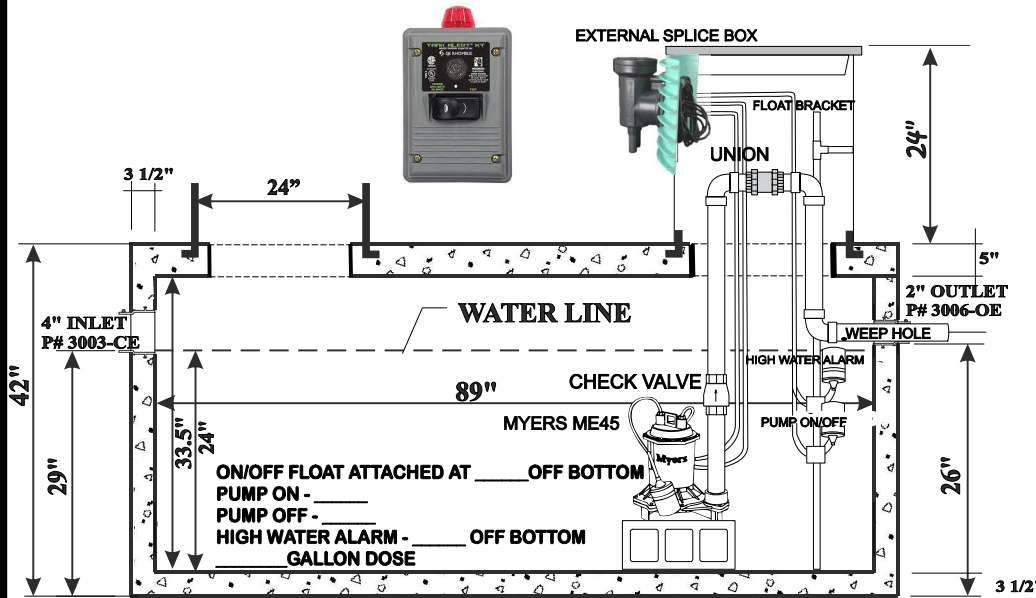

**POLYLOK**  
24" X 6" RISER



**POLYLOK 24" X 3"**  
RISER PAN

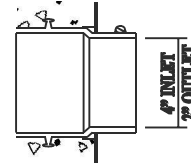
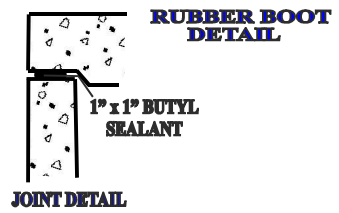

2" & 4" BOOT STANDARD  
CAST-IN WATERTIGHT RUBBER BOOTS

PROJECT		
CUSTOMER		
DRAWN BY		DATE
COST		
APPROVED BY		
DATE		

VOLUME - CAPACITY:	FABRICATION SPECS:
CAPACITY: 89" X 52" X 24" = 501 GAL	TONGUE & GROOVE JOINT, SEALED WITH 1" X 1" BUTYL SEALEANT
GALLONS PER INCH = 20.87 GAL	STRUCTURAL FIBER REINFORCED CONCRETE - 5000 PSI
	REINFORCEMENT - PROFIBER S PREMIERE STRUCTURAL FIBER
OVERALL WEIGHT : 7,000 LBS.	



29150 C DRIVE NORTH, ALBION, MI 49224  
PHONE: 517-629-4800 EXT:210